

Enterprise (1930)

Instructions:

Follow these instructions carefully and step by step. The rigging lines of the boat could tangle easily so do not undo the lines until instructed.

1. Unwrap the hull and stand. Place the hull into the stand with the hull facing forward to your right. Keep the starboard side of the boat facing you in order to follow the instructions and to compare with the diagrams.
- 1a. Study the open eyes of A, B, C, D, E, F, G, H & I, also traveler K, and other two cleats on the deck. They each have a fixed position that corresponds to different rigging lines and sail sheets of the boat. See diagram (1)
2. Unwrap the packing of the mast. You will find a brass hole near the bottom of the mast. The brass hole must face towards the stern of the yacht. Insert the mast into the mast step in the center of the deck.
- 2a. On the mast, you will find three sets of running backstay lines w/blocks and one set of forestay lines. Unfold the upper running backstay firstly and attach the lines to the brass eyes A, P & S side, on the rear of the deck. See diagram (2)
- 2b. Unfold the next lower group of running backstays with blocks on the mast. Attach the lines to the brass eyes B, P & S side, on the deck. Do the shortest backstay line which should attach to eyes C, P & S side. Then lead the forestay lines to eyes D, P & S side. See diagram (2).
- 2c. There are 3 spreaders with lines on the mast. Pls. unfold the lines. The upper spreader lines hook to eyes S1, the middle spreader lines to eyes S2 and the bottom spreader lines hook to eyes S3 on the center deck, P & S side. See diagram (1) & (2).
3. Unpack all of the sails. You may want to press the sails with an iron to get out any wrinkles. Each sail is numbered for convenience of set up. You should have sails 1, 2, 3, & 4. Do not remove the numbers until the set up is complete. Compare each with the diagram, which shows the exact location of each sail. See diagram (3)
- 3a. Hook the top of the main sail no.1 to the uppermost eye on the mast. Place the brass pin at the end of the boom into the hole near the bottom of the mast. See diagram (3)
- 3b. Fix a hook with double block at the other end of the boom to traveler K, hook the other two single blocks to eyes H, P & S side, leading the lines forward, then wrap the lines to two Cleats near center deck, P & S side. See diagram (3)
- 3c. Find sail no. 2. Hook the top of the sail to the appropriate eye at the front of the mast. The leading edge of sail no. 2 should attach to eye E. The sheet of the sail should attach to eye C, port-side, on the deck. See diagram (3)
- 3d. Find sail no. 3 and hook the top to the appropriate eye at the upper front of the mast. The leading edge of sail no. 3 should attach to eye F. The sheet of sail no. 3 should attach to eye I, port-sides, on the deck. See diagram (3).
- 3e. Now do sail no. 4. Hook the top of sail no. 4 to the topmost of mast. The leading edge of sail no. 4 should hook to eye F, the sheet of sail no. 4 should attach to eye G, port-side.

Your Sail Classics yacht should now be complete. Enjoy!

Sail Classics, Inc.
P.O. Box 747 Lakebay, WA 98349
Phone: 253-884-2267 Fax: 253-884-7858

Enterprise (1930)

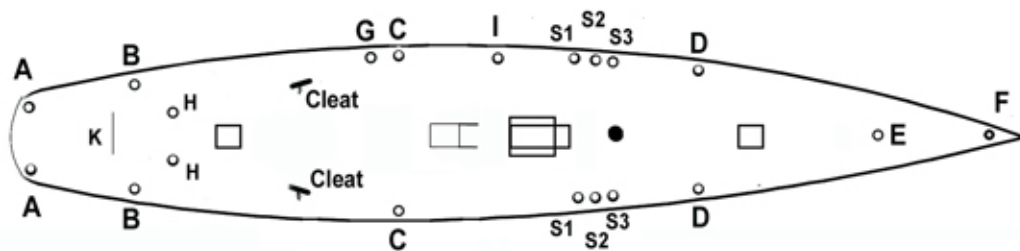

(1)

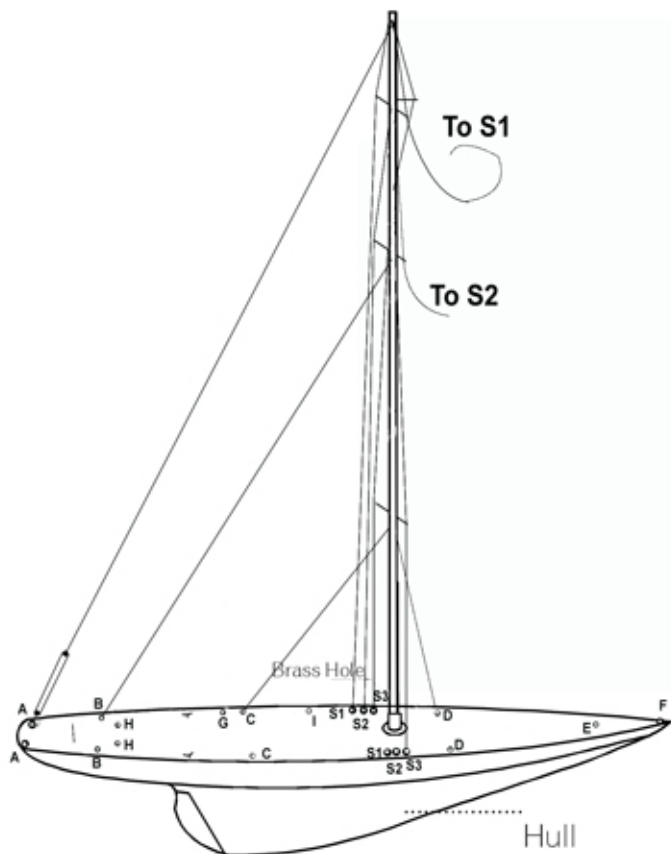

(2)

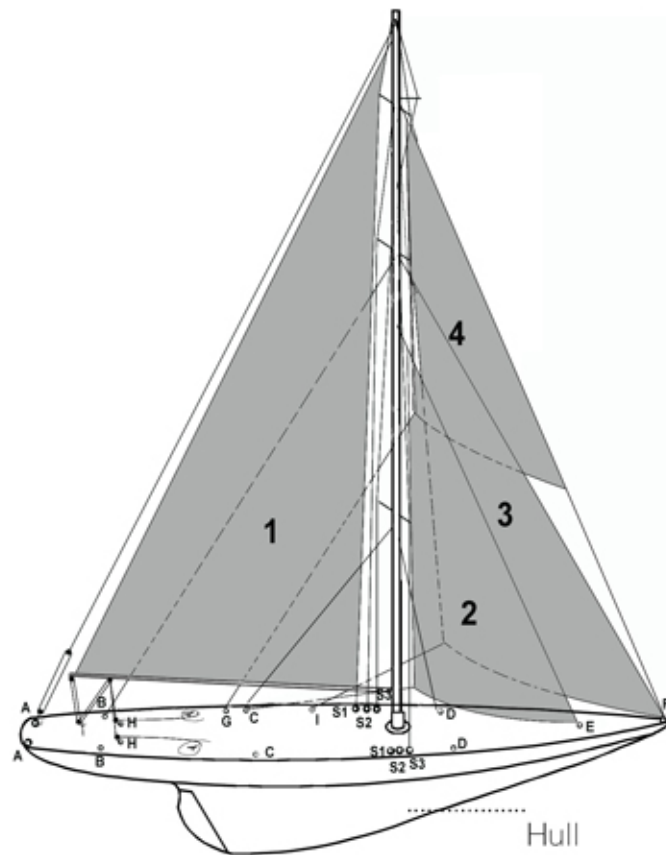

(3)